

Serie FRL Mini

 T010 Mini Pag. 20.7	 T015 Mini Pag. 20.9	 T020 Mini Pag. 20.11	 T070 Mini Pag. 20.13	 T080 Mini Pag. 20.15	 T030 Mini Pag. 20.17	 T040 Mini Pag. 20.19	 T100 Mini Pag. 20.21	 T400 Mini Pag. 20.23
 Accessories Pag. 20.25								

Serie FRL Evo

New

 Y010 Pag. 20.33	 Y015 Pag. 20.36	 Y020 Pag. 20.39	 Y025 Pag. 20.42	 Y030 Pag. 20.45	 Y040 Pag. 20.48	 Y050 Pag. 20.51	 Y051 Pag. 20.54	 Y052 Pag. 20.57
 Y060 Pag. 20.60	 Y090 Pag. 20.63	 Y100 Pag. 20.66	 Y400 Pag. 20.69	 Accessories Pag. 20.71				

Serie FRL Standard

 T010 Pag. 20.79	 T015 Pag. 20.82	 T020 Pag. 20.85	 T030 Pag. 20.88	 T040 Pag. 20.92	 T050 Pag. 20.96	 T060 Pag. 20.99	 T100 Pag. 20.102	 T110 Pag. 20.104
 T200 Pag. 20.106	 T210 Pag. 20.108	 T300 Pag. 20.110	 T400 Pag. 20.112	 T450 Pag. 20.114	 Accessories Pag. 20.116			

Manometri - Manometers - Manometer - Manomètre - Manómetro - Manómetro

 MAN01 MAN02 Pag. 20.119	 MAN03 MAN04 Pag. 20.119	 MAN05 Pag. 20.120	 MAN06 Pag. 20.120
--	--	--	--

Pressostati - Pressure Switches - Druckschalter - Pressostat - Presostatos - Pressostatos

 P31-P32 Pag. 20.121	 P49 Pag. 20.123	 P27 Pag. 20.125	 PR02 Pag. 20.127
--	--	--	---

Aignep si riserva il diritto di variare modelli e ingombri senza preavviso - Aignep reserves the right to vary models and dimensions without notice - Aignep behält sich das Recht vor, Daten ohne Ankündigung zu ändern
 Aignep se reserva el derecho de modificar modelos y dimensiones sin previo aviso - Aignep se réserve le droit de modifier les données sans préavis

COMPONENTI PER IL TRATTAMENTO DELL'ARIA COMPRESSA

AIR TREATMENT UNIT

DRUCKLUFTAUFBEREITUNG

UNITÉ DE TRAITEMENT D'AIR COMPRIMÉ

COMPONENTES PARA EL TRATAMIENTO DEL AIRE COMPRIMIDO

COMPONENTES PARA TRATAMENTO DE AR COMPRIMIDO



Serie FRL

I gruppi Trattamento Aria, chiamati comunemente FRL (F/filtro - R/regolatore - L/lubrificatore) sono l'elemento necessario in qualsiasi applicazione pneumatica per poter "condizionare" l'aria compressa che è tra le principale energia di cui si avvale l'automazione.

I gruppi FRL Aignep, realizzate in tecnopolimero e con filettature in metallo, sono disponibili in due serie, la serie definita MINI e quella STANDARD e coprono in maniera esauriente tutte le applicazioni anche le più esigenti.

Disponibili dall' 1/8" al 1" hanno portate molto elevate e sono altamente affidabili e corredati da tutte le gamme di accessori necessari.

Principali vantaggi

- Modularità semplificata
- Precisione ed affidabilità della regolazione
- Ottimizzazione delle portate
- Robustezza con peso limitato
- Elementi di filtrazione a coalescenza
- Silicon Free

Applicazioni

- Automazione Pneumatica
- Impianti Aria Compressa
- Compressori
- Circuiti aria compressa

The Air Preparation Units of Aignep are necessary for a perfect conditioning of compressed air.

Filters "F", Regulators "R" and Lubricators "L" are available in 4 sizes according to the flow and various combinations.

Size 0 "Mini" in 1/8-1/4" is constructed from high resistance & light technopolymers.

Sizes 1-2-3 is constructed from robust metal body and technopolymeric bowl form 1/8 to 1".

Fixing accessories to complete.

On demand FDA Filters

Main advantages

- Modularity
- Sharp and reliable regulation
- High Flow
- Robust with light weight
- Coalescing Filters
- Silicon Free

Applications

- Pneumatic Automation
- Compressed Air Circuit
- Compressors
- Compressed Air Pipeline

Die Druckluftaufbereitungseinheiten, gemeinhin bezeichnet als FRL: F Filter - R Regler - L Lubrifikator, sind notwendig für eine perfekte Aufbereitung von Druckluft. Sie sind in 4 Grössen erhältlich, dem Durchfluss und verschiedenen Kombinationen entsprechend.

Die Grösse 0 "Mini" 1/8 - 1/4" wird aus hochresistenten und leichten Technopolymeren hergestellt. Die Grössen 1-2-3 1/8 bis 1" haben ein robustes Metallgehäuse und eine Schalenform aus Technopolymer.

Befestigungszubehör zu Vervollständigung.

Die wichtigsten Vorteile

- Modularität
- Präzise und zuverlässige Regulierung
- Hoher Durchfluss
- Robust mit geringem Gewicht
- Koaleszierfiltern
- Silikonfrei

Anwendung

- Pneumatische Automation
- Druckluftkreislauf
- Kompressoren
- Druckluftleitung

Les unités de traitement d'air Aignep sont nécessaires pour un traitement parfait de l'air comprimé.

Filtres "F", Régulateurs "R" et Lubrificateurs "L" sont disponibles en 4 tailles en fonction du débit et des différentes combinaisons possibles.

La série "Mini" Taille 0, en 1/8-1/4 est fabriquée à partir de technopolymère Haute Résistance.

La série "Standard", Tailles 1-2-3 est construite à partir de corps métalliques robustes et de matériaux en technopolymère 1/8-1".

Une gamme Accessoires de fixation est également disponible.

Los grupos de tratamiento de aire, llamados comúnmente FRL, F filtro - R regulador - L lubricador - FR filtro regulador, son el elemento necesario en cualquier aplicación neumática para poder acondicionar el aire comprimido que es la principal energía en que se avala la automatización.

Los grupos FRL Aignep, realizados en tecnopolímero y con terminaciones metálicas, están disponibles en dos series, la serie denominada MINI y la serie STANDARD, y cubren de forma exhaustiva todas las aplicaciones incluso las más exigentes.

Disponibles desde 1/8" a 1" con caudales muy elevados y son altamente fiables y completados de toda la gama de accesorios necesarios.

As Unidades de Preparação de Ar da Aignep são necessárias para um perfeito condicionamento do ar comprimido. Filtros "F", Reguladores "R" e Lubrificadores "L" estão disponíveis em 4 tamanhos de acordo com a vazão necessária e várias combinações: O Tamanho 0 "Mini" com rosca de 1/8 e 1/4, é fabricado com tecnopolímeros de alta resistência e material leve.

Os Tamanhos 1-2-3 são fabricados com corpo em metal robusto e possuem copo em tecnopolímero, com rosca de 1/8 a 1". Completam os modelos todos os acessórios de fixação.

Principaux avantages

- Modularité
- Haut débit
- Robuste avec un poids léger
- Filtres coalescents
- Sans silicone

Principales ventajas

- Modularidad simplificada
- Precisión y fiabilidad de la regulación
- Optimización del caudal
- Robustez con peso limitado
- Elementos de filtración a coalescencia
- Libres de silicona

Principais vantagens

- Modularidade
- Precisão e confiabilidade de regulação
- Alta Vazão
- Robusto e leve
- Filtros Coalescentes disponíveis na linha
- Livre de Silicona

Applications

- Automatismes pneumatiques
- Circuits Air comprimé
- Compresseurs
- Réseaux air comprimé

Aplicaciones

- Automatización neumática
- Instalaciones de aire comprimido
- Compresores
- Circuitos de aire comprimido

Aplicação

- Automação Pneumática
- Circuitos de Ar Comprimido
- Compressores
- Redes de Ar Comprimido

MANOMETRI

MANOMETERS
MANOMETER
MANOMÈTRE
MANÓMETRO
MANÔMETRO



Norma di Riferimento

Reference standard

Entspricht der Norm

Norme de référence

Normativa de referencia

Norma de referência

EN 837-1



Fluidi compatibili

Aria / Gas Inerti / Vapori / Liquidi non altamente viscosi e non cristallizzanti

Fluids

Air / Inert gases / Steam / Non-highly viscose and non-crystallizing liquids

Geeignete Medien

Luft / Inertgase / Dampf / Nicht-hochviskose und nicht kristallisierende Flüssigkeiten

Fluides compatibles

Air / Gaz inertes / Vapeur / Liquides non hautement viscoses et non cristallisation

Fluidos compatibles

Aire / Gases inertes / Vapor / Líquidos no altamente viscosos y no cristalizantes

Fluidos compatíveis

Ar / Gases inertes / Vapor / Líquidos não altamente viscosos e não cristalizados

MAN01 / MAN02

IP31

MANOMETRO ATTACCO POSTERIORE

MANOMETER BACK CONNECTION

MANOMETER, ANSCHLUSS RÜCKSEITIG

MANOMÈTRE, RACCORD ARRIÈRE CENTRÉ

MANÓMETRO POSTERIOR

MANÔMETRO COM ROSCA TRASEIRA

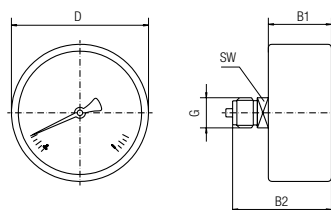

Code	bar	D	B1	B2	SW	G
MAN01 N2 020 000	0 ÷ 4	40	25	41.5	12	1/8
MAN01 N2 050 000	0 ÷ 6	40	25	41.5	12	1/8
MAN01 N2 060 000	0 ÷ 10	40	25	41.5	12	1/8
MAN01 N2 040 000	0 ÷ 12	40	25	41.5	12	1/8
MAN02 N2 050 000	0 ÷ 6	50	26	47	14	1/8
MAN02 N2 040 000	0 ÷ 12	50	26	47	14	1/8

	min	max
Temperature	- 20 °C	+ 60 °C

MAN03 / MAN04

IP31

MANOMETRO ATTACCO RADIALE

MANOMETER BOTTOM CONNECTION

MANOMETER, ANSCHLUSS RADIAL UNTEN

MANOMÈTRE, RACCORD VERTICAL

MANÓMETRO RADIAL

MANÔMETRO COM ROSCA RADIAL

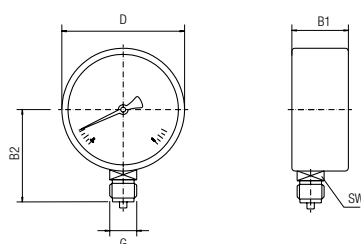

Code	bar	D	B1	B2	SW	G
MAN03 N2 050 000	0 ÷ 6	40	23.5	36	12	1/8
MAN03 N2 040 000	0 ÷ 12	40	23.5	36	12	1/8
MAN04 N2 040 000	0 ÷ 12	50	26	45	14	1/8

	min	max
Temperature	- 40 °C	+ 60 °C

MAN05

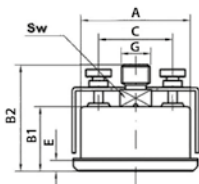
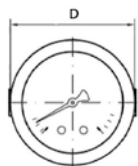
IP43
MANOMETRO ATTACCO POSTERIORE, FLANGIA CROMATA A SEZIONE TRIANGOLARE CON STAFFA
MANOMETER BACK CONNECTION, PANEL MOUNT WITH BRACKET
MANOMETER, RÜCKSEITIG MIT BÜGELBEFESTIGUNG
MANOMÈTRE, AVEC ÉTRIER DE FIXATION ARRIÈRE
MANÓMETRO POSTERIOR, BRIDA CROMADA A SECCIÓN TRIANGULAR CON SOPORTE
MANÓMETRO COM ROSCA TRASEIRA, FLANGE CROMADA COM SEÇÃO TRIANGULAR E SUPORTE

Code	bar	D	A	C	B1	B2	SW	E	G
MAN05 N2 020 000	0 ÷ 4	43	39	27.5	26	41.5	12	4.5	1/8
MAN05 N2 050 000	0 ÷ 6	43	39	27.5	26	41.5	12	4.5	1/8
MAN05 N2 060 000	0 ÷ 10	43	39	27.5	26	41.5	12	4.5	1/8
MAN05 N2 040 000	0 ÷ 12	43	39	27.5	26	41.5	12	4.5	1/8

	min	max
Temperature	- 40 °C	+ 60 °C

MAN06

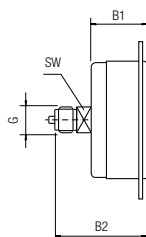
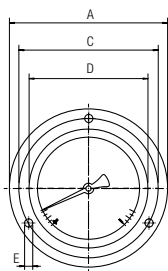
IP43
MANOMETRO ATTACCO POSTERIORE, FLANGIA ANTERIORE CROMATA A TRE FORI
MANOMETER BACK CONNECTION, 3 HOLES CHROMED FLANGE
MANOMETER, SCHALTTAFELEINBAU
MANOMÈTRE, ENCASTRABLE
MANÓMETRO POSTERIOR, BRIDA ANTERIOR CROMADA A 3 TALADROS
MANÓMETRO COM ROSCA TRASEIRA, FLANGE FRONTAL CROMADA COM TRÊS FUROS



Code	bar	D	A	C	E	B1	B2	SW	G
MAN06 N2 020 000	0 ÷ 4	40	61	51	3.6	26	42.5	12	1/8
MAN06 N2 050 000	0 ÷ 6	40	61	51	3.6	26	42.5	12	1/8
MAN06 N2 060 000	0 ÷ 10	40	61	51	3.6	26	42.5	12	1/8
MAN06 N2 040 000	0 ÷ 12	40	61	51	3.6	26	42.5	12	1/8

	min	max
Temperature	- 40 °C	+ 60 °C

New





PRESSOSTATI A MEMBRANA ≤ 250V





DIAPHRAGM PRESSURE SWITCH ≤ 250V
 MEMBRANDRUCKSCHALTER ≤ 250V
 PRESSOSTAT A MEMBRANE ≤ 250V
 PRESOSTATOS DE MEMBRANA ≤ 250V
 PRESSOSTATO DE MEMBRANA ≤ 250V

 **CARATTERISTICHE TECNICHE**
 TECHNICAL CHARACTERISTICS
 TECHNISCHE ANGABEN
 CARACTÉRISTIQUES TECHNIQUES
 CARACTERÍSTICAS TÉCNICAS
 CARACTERÍSTICAS TÉCNICAS

 **Norma di Riferimento**
 Reference standard
 Entspricht der Norm
 Norme de référence
 Normativa de referencia
 Norma de referência

1907/2006 **REACH** ✓
 2011/65/CE **RoHS** ✓
 PED 2014/68/UE
IP65

	CONTATTI ELETTRICI ELECTRICAL CONTACTS ELEKTRISCHE KONTAKTE CONTACT ELECTRIQUE CONTACTOS ELÉCTRICOS	ARGENTO AgNi SILVER AgNi SILBER AgNi ARGENT AgNi PLATA AgNi PRATA AgNi
	MAX TEMPERATURA FLUIDO MAX FLUID TEMPERATURE MAX. FLÜSSIGKEITSTEMPERATUR TEMPERATURE MAXI FLUIDE MAX TEMPERATURA FLUIDO TEMPERATURA MÁX. DO FLUIDO	120 °C
	MAX TENSIONE COMMUTABILE MAX SWITCHING TENSION MAX. SCHALTSPANNUNG COMMUTATION TENSION MAX MAX TENSION CONMUTABLE TENSÃO MAX. DE COMUTAÇÃO	250V
	MAX CORRENTE COMMUTABILE MAX SWITCHING VOLTAGE MAX. SCHALTSTROM COMMUTATION COURANT MAX MAX CORRIENTE CONMUTABLE CORRENTE MÁX. DE COMUTAÇÃO	0,5 A
	FLUIDO FLUID MEDIEN FLUIDE FLUIDO FLUIDO	Gas, Aria, Acqua, Olio, Benzina, Solventi, Silicone Gas, Air, Water, Oil, Petrol, Solvents, Silicone Gas, Luft, Wasser, Öl, Benzin, Lösungsmittel, Silikon Gaz, Air, Eau, Huile, essence, Solvants, silicone Gas, Aire, Agua, En aceite, Gasolina, Solvente, Silicona Gás, ar, água, óleo, gasolina, solventes, silicone

	VITA MECCANICA MECHANICAL LIFE MECHANISCHE LEBENSDAUER DUREE DE VIE MECANIQUE VIDA MECÁNICA VIDA ÚTIL MECÁNICA	1 MILIONE DI CICLI 1 MILION CYCLES 1 MILLION ZYKLEN 1 MILLIONS DE CYCLES 1 MILLONES DE CICLOS 1 MILHÃO DE CICLOS
	VITA ELETTRICA ELECTRICAL LIFE ELEKTRONISCHE LEBENSDAUER VIE ÉLECTRIQUE VIDA ELÉCTRICA VIDA ÚTIL ELÉCTRICA	100.000 CICLI 100.000 CYCLES 100.000 ZYKLEN 100.000 CYCLES 100.000 CICLOS 100.000 CICLOS
	MAX PRESSIONE DI LAVORO MAX WORKING PRESSURE MAX. BETRIEBSDRUCK PRESSION UTILISATION MAXIMALE MAX PRESIÓN DE FUNCIONAMIENTO PRESSÃO MÁXIMA DE TRABALHO	40 bar
	MAX PRESSIONE DI SICUREZZA MAX SAFETY PRESSURE MAX. SICHERHEITSDRUCK PRESSION MAX DE SECURITE MAX PRESIÓN DE SEGURIDAD PRESSÃO MÁX. DE SEGURANÇA	80 bar
	TIPO DI AZIONAMENTO DRIVE TYPE ART DES ANTRIEBS TYPE D'ACTIONNEMENT TIPO DE ACCIONAMIENTO TIPO DE ACIONAMENTO	1 B

 **Tabella dei codici di ordinazione**
 Ordering codes
 Bestellschlüssel
 Code de commande
 Tabla de codificación para pedidos
 Tabela de codificação para compra

SERIE	Funzione Function Funktion Función Función Funcões	Filetto conico Thread taper Gewinde konisch Taraudage conique Rosca cónica Rosca cónica	Campo di regolazione Regulation Range Regelbereich Plage de Réglage Campo de Regulación Faixa de Regulagem
P 3	1 1 = NO 2 = NC	1 8 18 = 1/8 14 = 1/4	0 1 01 = 0.1 ÷ 1 bar 02 = 1 ÷ 10 bar 03 = 10 ÷ 20 bar

P31 - P32

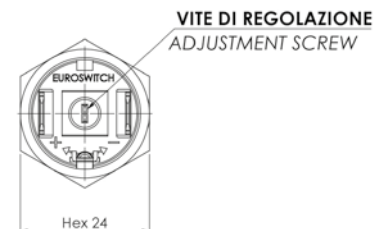
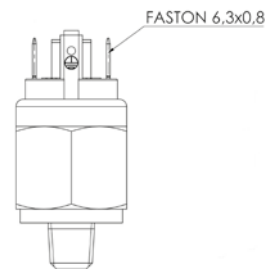
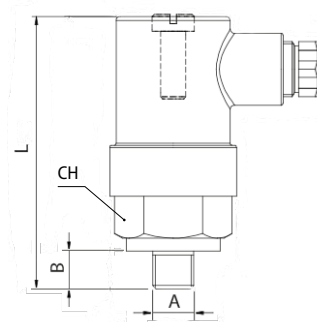

Materiali e Componenti	IT	Materials and components	GB	Komponenten und Materialien	DE
<ul style="list-style-type: none"> 1 Corpo in ottone 2 Cappuccio di protezione IP65 3 Membrana FKM 		<ul style="list-style-type: none"> 1 Brass body 2 Safety pad IP65 3 Diaphragm FKM 		<ul style="list-style-type: none"> 1 Körper Messing 2 Schutzkappe IP65 3 Membran FKM 	
Matériaux et Composants	FR	Materiales y componentes	ES	Materiais e Componentes	PT
<ul style="list-style-type: none"> 1 Corps en laiton 2 Capuchon de protection IP65 3 Membrane FKM 		<ul style="list-style-type: none"> 1 Cuerpo en latón 2 Tapa protectora IP65 3 Membrana FKM 		<ul style="list-style-type: none"> 1 Corpo em latão 2 Capa de proteção IP65 3 Membrana em FKM 	

Standard code in stock	A	B	L	CH	Funzione Function Funktion Fonction Función Funções	Regolazione Regulation Regelbereich Réglage Regulación Regulagem	Tolleranza 20°C Tolerance 20°C Toleranz bei 20°C Tolérance 20°C Tolerancia 20°C Tolerância a 20°C
P3 1 18 01	1/8	10	65	24	NO	0.1 ÷ 1 bar	± 0.1 bar
P3 1 18 02	1/8	10	65	24	NO	1 ÷ 10 bar	± 0.5 bar
P3 1 18 03	1/8	10	65	24	NO	10 ÷ 20 bar	± 1.0 bar
P3 1 14 01	1/4	12	67	24	NO	0.1 ÷ 1 bar	± 0.1 bar
P3 1 14 02	1/4	12	67	24	NO	1 ÷ 10 bar	± 0.5 bar
P3 1 14 03	1/4	12	67	24	NO	10 ÷ 20 bar	± 1.0 bar
P3 2 18 01	1/8	10	65	24	NC	0.1 ÷ 1 bar	± 0.1 bar
P3 2 18 02	1/8	10	65	24	NC	1 ÷ 10 bar	± 0.5 bar
P3 2 18 03	1/8	10	65	24	NC	10 ÷ 20 bar	± 1.0 bar
P3 2 14 01	1/4	12	67	24	NC	0.1 ÷ 1 bar	± 0.1 bar
P3 2 14 02	1/4	12	67	24	NC	1 ÷ 10 bar	± 0.5 bar
P3 2 14 03	1/4	12	67	24	NC	10 ÷ 20 bar	± 1.0 bar

New

PRESSOSTATI A MEMBRANA CON CONTATTI IN SCAMBIO

DIAPHRAGM PRESSURE SWITCH WITH EXCHANGE CONTACTS
 MEMBRANDRUCKSCHALTER MIT WECHSELKONTAKTEN
 PRESSOSTAT A MEMBRANE AVEC ECHANGE CONTACTS (SPDT)
 PRESOSTATOS DE MEMBRANA CON CONTACTOS EN INTERCAMBIO
 PRESSOSTATO DE MEMBRANA - CONTATO DE 1 PÓLO ACIONAMENTO DUPLO



CARATTERISTICHE TECNICHE
 TECHNICAL CHARACTERISTICS
 TECHNISCHE ANGABEN
 CARACTÉRISTIQUES TECHNIQUES
 CARACTERÍSTICAS TÉCNICAS
 CARACTERÍSTICAS TÉCNICAS



Norma di Riferimento
 Reference standard
 Entspricht der Norm
 Norme de référence
 Normativa de referencia
 Norma de referência

1907/2006
REACH

2011/65/CE

PED
 2014/68/UE

IP65

	CONTATTI ELETTRICI ELECTRICAL CONTACTS ELEKTRISCHE KONTAKTE CONTACTS ELECTRIQUES CONTACTOS ELÉCTRICOS CONTATOS ELÉTRICOS	ARGENTO SILVER SILBER ARGENT PLATA PRATA
	CARATTERISTICHE ELETTRICHE ELECTRICAL FEATURES ELEKTRISCHE EIGENSCHAFTEN CARACTÉRISTIQUES ELECTRIQUES CARACTERÍSTICAS ELÉCTRICAS CARACTERÍSTICAS ELÉTRICAS	5 (4) A / 14 Vdc 4 (3) A / 30 Vdc 5 (3) A / 125 Vac 3 (2) A / 250 Vac
	CONDIZIONE ELETTRICA ELECTRICAL CONDITION ELEKTRISCHE BEDINGUNG CONDITION ELECTRIQUE CONDICIÓN ELÉCTRICA CONDIÇÃO ELÉTRICA	SPDT CONTATTI SPDT CONTACTS SPDT WECHSELKONTAKTE SPDT CONTACTS SPDT CONTACTOS SPDT CONTATOS
	MAX TEMPERATURA FLUIDO MAX FLUID TEMPERATURE MAX. FLÜSSIGKEITSTEMPERATUR TEMPERATURE MAX FLUIDE MAX TEMPERATURA FLUIDO TEMPERATURA MÁX. DO FLUIDO	120 °C
	MAX CORRENTE COMMUTABILE MAX SWITCHING VOLTAGE MAX. SCHALTSTROM COMMUTATION COURANT MAX MAX CORRIENTE COMMUTABLE CORRENTE MÁX. DE COMUTAÇÃO	0,5 A
	FLUIDO FLUID MEDIEN FLUIDE FLUIDO FLUIDO	Gas, Aria, Acqua, Olio, Benzina, Solventi, Silicone Gas, Air, Water, Oil, Petrol, Solvents, Silicone Gas, Luft, Wasser, Öl, Benzin, Lösungsmittel, Silikon Gaz, Air, Eau, Huile, essence, Solvants, silicone Gas, Aire, Agua, En aceite, Gasolina, Solvente, Silicona Gás, ar, água, óleo, gasolina, solventes, silicone

	VITA MECCANICA MECHANICAL LIFE MECHANISCHE LEBENSDAUER DUREE DE VIE MECANIQUE VIDA MECÁNICA VIDA ÚTIL MECÁNICA	1 MILIONE DI CICLI 1 MILION CYCLES 1 MILLION ZYKLEN 1 MILLIONS DE CYCLES 1 MILLONES DE CICLOS 1 MILHÃO DE CICLOS
	GRANO DI REGOLAZIONE REGULATION PIN REGULIERSTIFT VIS DE REGULATION TORNILLO DE REGULACIÓN PARAFUSO DE REGULAGEM	CHIAVE BRUGOLA DA 1.5 mm 1.5mm ALLEN WRENCH INBUSSCHRAUBE 1.5 mm CLEF ALLEN DE 1.5mm LLAVE ALLEN DE 1.5mm CHAVE ALLEN DE 1.5mm
	MAX PRESSIONE DI LAVORO MAX WORKING PRESSURE MAX. BETRIEBSDRUCK PRESSION UTILISATION MAX MAX PRESIÓN DE FUNCIONAMIENTO PRESSÃO MÁX. DE TRABALHO	40 bar
	MAX PRESSIONE DI SICUREZZA MAX SAFETY PRESSURE MAX. SICHERHEITSDRUCK PRESSION MAX DE SECURITE MAX PRESIÓN DE SEGURIDAD PRESSÃO MÁX. DE SEGURANÇA	80 bar
	COPPIA MAX DI SERRAGGIO MAX TORQUE MAX. ANZUGSMOMENT COUPLE DE SERRAGE MAX PAR MAX DE APRIETE TORQUE MÁX. DE APERTO	25/50 Nm
	TIPO DI AZIONAMENTO DRIVE TYPE ART DES ANTRIEBS TYPE D'ACTIONNEMENT TIPO DE ACCIONAMIENTO TIPO DE ACIONAMENTO	1 B
	ISTERESI HYSTERESIS HYSTERESEKURVE HYSTÉRÉSIS HISTÉRESIS HISTERESE	10 ÷ 30 %



Tabella dei codici di ordinazione
 Ordering codes
 Bestellschlüssel
 Code de commande
 Tabla de codificación para pedidos
 Tabela de codificação para compra

SERIE	Filetto conico Thread taper Gewinde konisch Taraudage conique Rosca cónico Rosca cónica	Campo di regolazione Regulation Range Regelbereich Plage de Réglage Campo de Regulación Faixa de Regulagem
P 4 9	1 8 18 = 1/8 14 = 1/4	0 1 01 = 0.3 ÷ 1.5 bar 02 = 1 ÷ 12 bar 03 = 10 ÷ 40 bar

P49

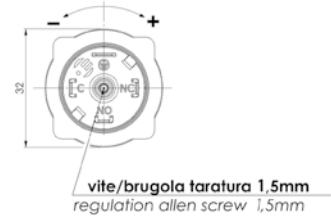
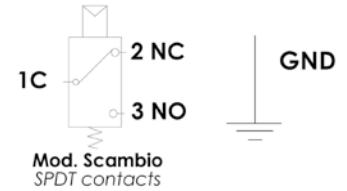
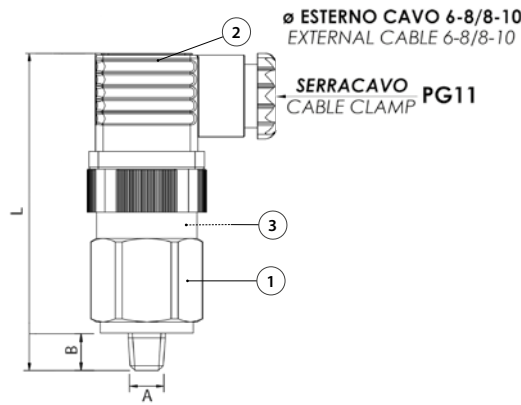

Materiali e Componenti	IT	Material and components	GB	Komponenten und Materialien	DE
1 Corpo in ottone 2 Connettore IP65 3 Membrana FKM		1 Brass Body 2 Connector IP65 3 Diaphragm FKM		1 Körper Messing 2 Stecker IP65 3 Membran FKM	
Matériaux et Composants	FR	Materiales y componentes	ES	Materiais e Componentes	PT
1 Corps en laiton 2 Connecteur IP65 3 Membrane FKM		1 Cuerpo en latón 2 Conector IP65 3 Membrana FKM		1 Corpo em latão 2 Conector IP65 3 Membrana em FKM	

Standard code in stock	A	B	L	CH	Regolazione Regulation Regelbereich Réglage Regulación Regulagem	Tolleranza 20°C Tolerance 20°C Toleranz bei 20°C Tolérance 20°C Tolerancia 20°C Tolerância a 20°C
P49 18 01	1/8	10	85	27	0.3 ÷ 1.5 bar	± 0.15 bar
P49 18 02	1/8	10	85	27	1 ÷ 12 bar	± 0.50 bar
P49 18 03	1/8	10	85	27	10 ÷ 40 bar	± 2.00 bar
P49 14 01	1/4	12	87	27	0.3 ÷ 1,5 bar	± 0.15 bar
P49 14 02	1/4	12	87	27	1 ÷ 12 bar	± 0.50 bar
P49 14 03	1/4	12	87	27	10 ÷ 40 bar	± 2.00 bar

New

PRESSOSTATI A MEMBRANA - ISTERESI REGOLABILE - CONTATTI IN SCAMBIO

DIAPHRAGM PRESSURE SWITCH - ADJUSTABLE HYSTERESIS - EXCHANGE CONTACTS
 MEMBRANDRUCKSCHALTER - EINSTELLBARE HYSTERESE - WECHSELKONTAKTE
 PRESSOSTAT A MEMBRANE - HYSTERESIS - ECHANGE CONTACT (SPDT)
 PRESOSTATOS DE MEMBRANA - HISTÉRESIS AJUSTABLE- CONTACTOS EN INTERCAMBIO
 PRESSOSTATO DE MEMBRANA - HISTERESE AJUSTÁVEL - CONTATO DE 1 PÓLO ACIONAMENTO DUPLO



CARATTERISTICHE TECNICHE
 TECHNICAL CHARACTERISTICS
 TECHNISCHE ANGABEN
 CARACTÉRISTIQUES TECHNIQUES
 CARACTERÍSTICAS TÉCNICAS
 CARACTERÍSTICAS TÉCNICAS



Norma di Riferimento
 Reference standard
 Entspricht der Norm
 Norme de référence
 Normativa de referencia
 Norma de referência

1907/2006
REACH ✓

2011/65/CE
 RoHS ✓

PED
 2014/68/UE

IP65

	CONTATTI ELETTRICI ELECTRICAL CONTACTS ELEKTRISCHE KONTAKTE CONTACTS ELECTRIQUES CONTACTOS ELÉCTRICOS CONTATOS ELÉTRICOS	ARGENTO SILVER SILBER ARGENT PLATA PRATA
	CARATTERISTICHE ELETTRICHE ELECTRICAL FEATURES ELEKTRISCHE EIGENSCHAFTEN CARACTÉRISTIQUES ELECTRIQUES CARACTERÍSTICAS ELÉCTRICAS CARACTERÍSTICAS ELÉTRICAS	4 (2) A / 24 Vdc 6 (2) A / 250 Vac
	CONDIZIONE ELETTRICA ELECTRICAL CONDITION ELEKTRISCHE BEDINGUNG CONDITION ELECTRIQUE CONDICIÓN ELÉCTRICA CONDIÇÃO ELÉTRICA	SPDT CONTATTI SPDT CONTACTS SPDT WECHSELKONTAKTE SPDT CONTACTS SPDT CONTACTOS SPDT CONTATOS
	MAX TEMPERATURA FLUIDO MAX FLUID TEMPERATURE MAX. FLÜSSIGKEITSTEMPERATUR TEMPERATURE MAX DU FLUIDE MAX TEMPERATURA FLUIDO TEMPERATURA MÁX. DO FLUIDO	120 °C
	FLUIDO FLUID MEDIEN FLUIDE FLUIDO FLUIDO	Gas, Aria, Acqua, Olio, Benzina, Solventi, Silicone Gas, Air, Water, Oil, Petrol, Solvents, Silicone Gas, Luft, Wasser, Öl, Benzin, Lösungsmittel, Silikon Gaz, Air, Eau, Huile, essence, Solvants, silicone Gas, Aire, Agua, En aceite, Gasolina, Solvente, Silicona Gás, ar, água, óleo, gasolina, solventes, silicone

	VITA MECCANICA MECHANICAL LIFE MECHANISCHE LEBENSDAUER DUREE DE VIE MECANIQUE VIDA MECÁNICA VIDA ÚTIL MECÁNICA	1 MILIONE DI CICLI 1 MILION CYCLES 1 MILLION ZYKLEN 1 MILLIONS DE CYCLES 1 MILLONES DE CICLOS 1 MILHÃO DE CICLOS
	MAX PRESSIONE DI LAVORO MAX WORKING PRESSURE MAX. BETRIEBSDRUCK PRESSION MAX D'UTILISATION MAX PRESIÓN DE FUNCIONAMIENTO PRESSÃO MÁX. DE TRABALHO	Ottone 40 bar / Acciaio 50 bar Brass 40 bar / Stainless 50 bar Messing 40 bar / Edelstahl 50 bar Laiton 40 bar / Acier 50 bar Latón 40 bar / Acero 50 bar Latão 40 bar / Aço 50 bar
	MAX PRESSIONE DI SICUREZZA MAX SAFETY PRESSURE MAX. SICHERHEITSDRUCK PRESSION MAX DE SECURITE MAX PRESIÓN DE SEGURIDAD PRESSÃO MÁX. DE SEGURANÇA	Ottone 80 bar / Acciaio 300 bar Brass 80 bar / Stainless 300 bar Messing 80 bar / Edelstahl 300 bar Laiton 80 bar / Acier 300 bar Latón 80 bar / Acero 300 bar Latão 80 bar / Aço 300 bar
	TIPO DI AZIONAMENTO DRIVE TYPE ART DES ANTRIEBS TYPE D'ACTIONEMENT TIPO DE ACCIONAMIENTO TIPO DE ACCIONAMENTO	1 B
	ISTERESI HYSTERESIS HYSTERESEKURVE HYSTÉRESIS HISTÉRESIS HISTERESE	10 ÷ 50 % Regolabile 10 ÷ 50 % Adjustable 10 ÷ 50 % Verstellbar 10 ÷ 50 % Réglable 10 ÷ 50 % Ajustable 10 ÷ 50 % Regulável



Tabella dei codici di ordinazione

- Ordering codes
- Bestellschlüssel
- Code de commande
- Tabla de codificación para pedidos
- Tabela de codificação para compra



P 2 7

1 8

0 1

18 = 1/8
14 = 1/4

01 = 0,3 ÷ 1,5 bar
02 = 1 ÷ 10 bar
03 = 10 ÷ 50 bar

P27

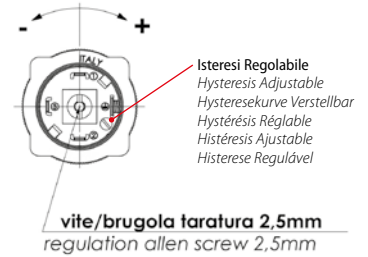
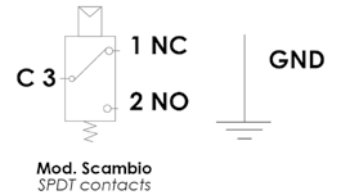
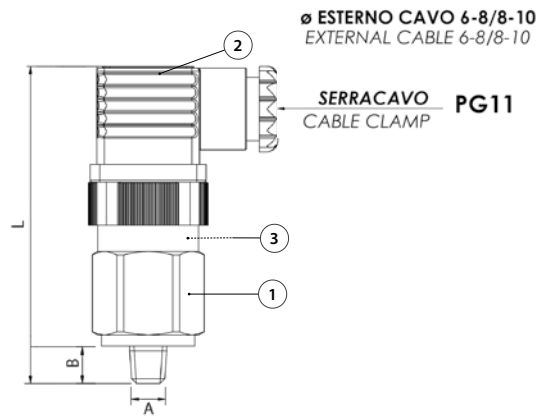

Materiali e Componenti	IT	Material and components	GB	Komponenten und Materialien	DE
1 Corpo in ottone o acciaio 2 Connettore IP65 3 Membrana FKM		1 Brass Body or stainless 2 Connector IP65 3 Diaphragm FKM		1 Körper Messing oder edelstahl 2 Stecker IP65 3 Membran FKM	
Matériaux et Composants	FR	Materiales y componentes	ES	Materiais e Componentes	PT
1 Corps en laiton ou acier 2 Connecteur IP65 3 Membrane FKM		1 Cuerpo en latón o acero 2 Conector IP65 3 Membrana FKM		1 Corpo em latão ou Aço 2 Conector IP65 3 Membrana em FKM	

Standard code in stock	A	B	L	CH	Regolazione Regulation Regelbereich Réglage Regulación Regulagem	Tolleranza 20°C Tolerance 20° Toleranz bei 20°C Tolérance 20°C Tolerancia 20°C Tolerância a 20°C
P27 18 01	1/8	10	83	27	0,3 ÷ 1,5 bar	± 0,20 bar
P27 18 02	1/8	10	83	27	1 ÷ 10 bar	± 0,50 bar
* P27 18 03	1/8	10	83	27	10 ÷ 50 bar	± 2,00 bar
P27 14 01	1/4	12	85	27	0,3 ÷ 1,5 bar	± 0,20 bar
P27 14 02	1/4	12	85	27	1 ÷ 10 bar	± 0,50 bar
* P27 14 03	1/4	12	85	27	10 ÷ 50 bar	± 2,00 bar

* CORPO: Acciaio - BODY: Steel - KÖRPER: Stahl - CORPS: Acier - CUERPO: Acero - CORPO: Aço

SENSORI DI PRESSIONE

PRESSURE SWITCHES
DRUCKSCHALTER
PRESSOSTAT
PRESOSTATOS
PRESSOSTATOS



CARATTERISTICHE TECNICHE
TECHNICAL CHARACTERISTICS
TECHNISCHE ANGABEN
CARACTÉRISTIQUES TECHNIQUES
CARACTERÍSTICAS TÉCNICAS
CARACTERÍSTICAS TÉCNICAS



1907/2006
REACH ✓
2011/65/CE
RoHS ✓



Installazione rapida

Quick installation
Schnelle Installation
Installation rapide
Instalación rápida
Instalação rápida

- **Risparmio tempo d'installazione**
Save installation time
Spart Installationszeit
Réduction du temps d'installation
Ahorro tiempo de instalación
Redução no tempo de instalação
- **Semplice da rimuovere**
Easy removal
Einfach zu entfernen
Simple à enlever
Fácil de desmontar
Simples de remover

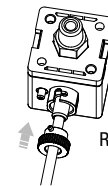

Removable data cable

Copia dei settaggi

Copy setting
Kopie der Einstellungen
Paramètres
Copia de ajuste
Cópia dos ajustes

- **Evita errori di settaggio**
Avoid setting errors
Vermeidet Einstellungsfehler
Évite les erreurs de réglage
Evita errores de ajuste
Evita erros de ajuste
- **Riduce il tempo di settaggio**
Reduce setting time
Reduziert die Einstellungszeit
Réduit le temps de réglage
Reduce el tiempo de ajuste
Reduz tempo de ajuste



(Original Parameter) (Copied)

Semplice identificazione dell'unità

Easy unit identification
Einfache Geräteidentifikation
Identification facile de l'unité de mesure
Simple identificación de la unidad
Identificação simples da unidade

- **Le unità di misura sono sul display e semplici da leggere**
Conversion unit is on display and easy to read
Die Masseinheiten sind auf dem Display und leicht zu lesen
Affichage de l'unité de mesure facile à lire
Las unidades de medida están en el display, y son fáciles de leer
As unidades de medida estão no display e fáceis de ler



Display a 2 colori

2-Color display
2-farbiger Display
Affichage à 2 couleurs
Display de 2 colores
Display em duas cores

- **Programmare il colore per differenti condizioni di settaggio**
User programmable color mode, for different dsetting conditions
Programmierbare Farben für verschiedene Einstellungsbedingungen
Configurer la couleur suivant le type de réglage
Programar el color para diferentes condiciones de introducción de datos
Programar a cor para diferentes condições de ajuste



Protezione IP65

IP65 Enclosure
Schutzart IP65
Protection IP65
Protección IP65
Proteção IP65

- **Protezione da acqua e polvere da tutte le direzioni**
Protected against water and dust splash from all directions
Schutz gegen Wasser und Staub aus allen Richtungen
Protection contre projection d'eau et milieu poussiéreux
Protección del agua y del polvo en todas las direcciones
Proteção de água e pó de todas as direções





Descrizione del pannello	IT	Panel description	GB	Panel-Beschreibung	DE
1 Indicatore uscita 1 2 Indicatore uscita 2 3 Pulsanti d'incremento e decremento 4 Pulsanti di settaggio 5 Selezione unità di misura 6 Display a 2 colori		1 Output 1 indicator 2 Output 2 indicator 3 Up/Down button 4 Setting button 5 Pressure Unit display section 6 2 color display		1 Anzeige Ausgang 1 2 Anzeige Ausgang 2 3 Up/Down Taste 4 Einstelltasten 5 Auswahl der Masseinheit 6 2-farbiger Display	
Description de l'affichage	FR	Descripción del panel	ES	Descrição do painel	PT
1 Indicateur sortie 1 2 Indicateur sortie 2 3 Position plus/moins 4 Bouton de réglage 5 Sélection de l'unité de mesure 6 Affichage à 2 couleurs		1 Indicador salida 1 2 Indicador salida 2 3 Pulsador de incremento y decremento 4 Pulsador de ajuste 5 Selección unidad de medida 6 Display de 2 colores		1 Indicador saída 1 2 Indicador saída 2 3 Botão de incremento e decremento 4 Botão de ajuste 5 Seleção da unidade de medida 6 Display com 2 cores	



Codice e diagramma cablaggio circuito di uscita

- Code and output circuit wiring diagrams
- Code und Ausgangsschaltpläne
- Code et schéma de câblage du circuit de sortie
- Código y esquema de conexiones del circuito de salida
- Código e Diagrama de ligação do circuito de saída

**PR02 P 02 P1 (Pressure)
PR02 V 02 P1 (Vacuum)**

2 PNP + Analog Output (1~5V)

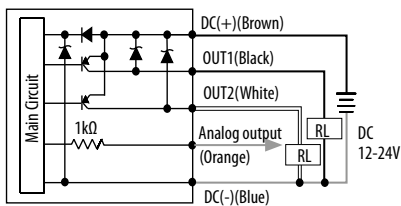

**PR02 P 02 P2 (Pressure)
PR02 V 02 P2 (Vacuum)**

2 PNP + Analog Output (4~20mA)

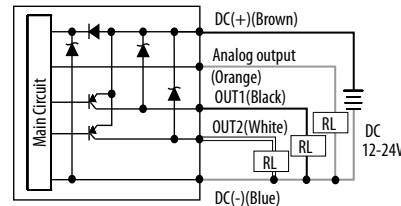

**PR02 P 02 PC (Pressure)
PR02 V 02 PC (Vacuum)**

2 PNP + Copy Function

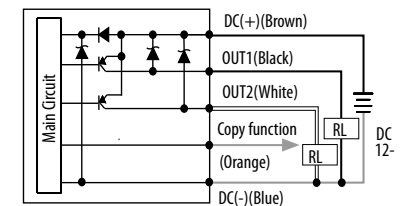

Dimensioni

- Dimensions
- Abmessungen
- Dimensions
- Dimensiones
- Dimensões

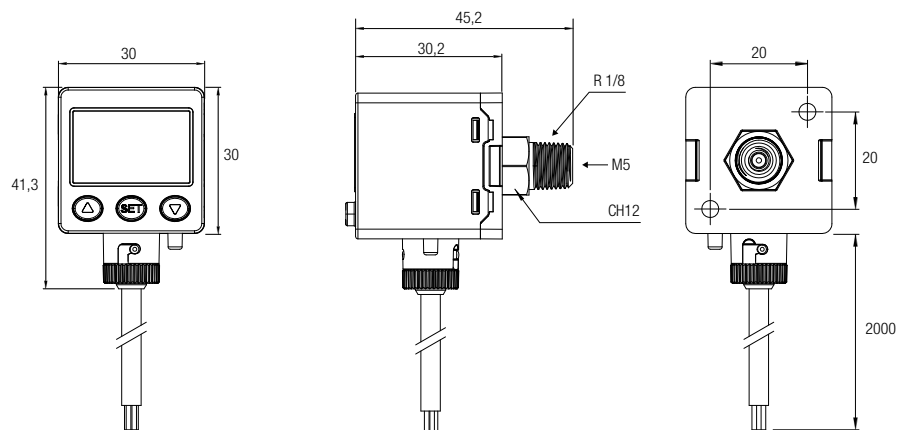
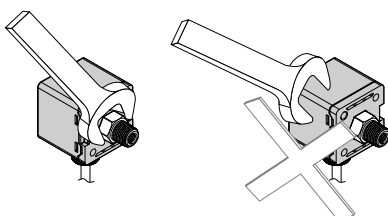



Accessori

Accessories

Zubehör

Accessoires

Accesorios

Acessórios



PR02B1

PR02B2



PR02B3

SQUADRETTA DI MONTAGGIO

MOUNTING BRACKET

BEFESTIGUNGSWINKEL

UNITE D'ASSEMBLAGE

SOPORTE DE MONTAJE

SUPORTE DE MONTAGEM

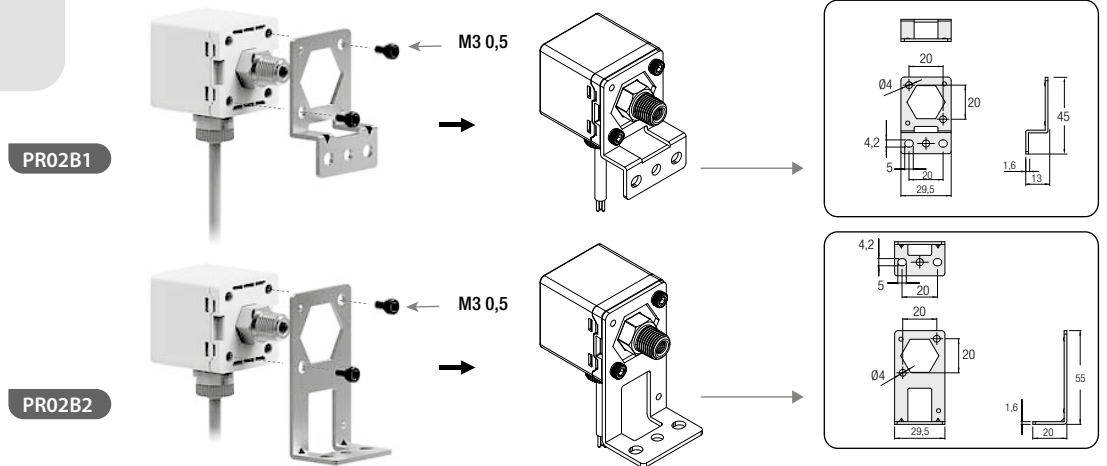

ADATTATORE PANNELLO + COPERCHIO FRONTALE

PANEL MOUNT ADAPTER + FRONT PROTECTIVE LID

PANEL BEFESTIGUNG + FRONT ABDECKUNG

PANNEAU ADAPTEUR + COUVERCLE FRONTAL

ADAPTADOR PANEL + CUERPO FRONTAL

ADAPTADOR PARA PAINEL + COBERTURA FRONTAL

PROTEZIONE IP65

IP65 ENCLOSURE

SCHUTZART IP65

PROTECTION IP65

PROTECCIÓN IP65

PROTEÇÃO IP65

PR02B3

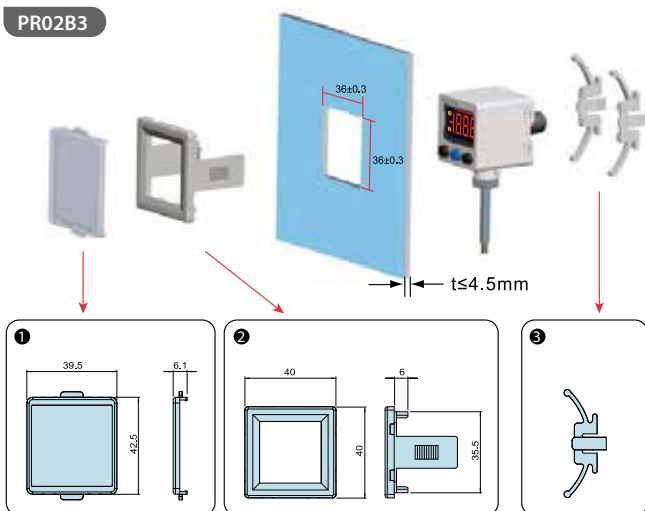

1 Coperchio frontale
Front Protective Lid
Frontabdeckung
Couvercle frontal
Cuerpo frontal
Cobertura frontal

2 3 Adattatore per pannello
Panel Adapter
Panel Befestigung
Panneau adaptateur
Adaptador para panel
Adaptador para painel

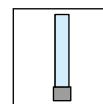
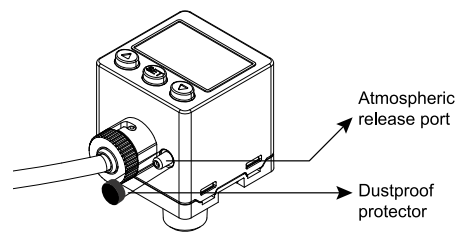

- NB: Questo componente deve essere installato per mantenere la classe IP65 (a prova di polvere e spruzzi).
This device must be installed to maintain IP65 (dust and splash proof) enclosure rating.
Hinweis: Diese Komponente muss installiert werden um die Schutzart IP65 (staub- und spritzwasserdicht) zu halten.
NB: Ce composant doit être installé pour maintenir la classe IP65, à l'épreuve de la poussière et projections d'eau.
Este componente debe ser instalado para mantener la clase IP65 (a prueba de polvo y salpicaduras).
OBS: Este componente deve ser instalado para manter a classe IP65 (a prova de pó e jato).

MODEL		PR02 V (Vacuum)	PR02 P (Pressure)		
Range di pressione <i>Rated pressure range</i> <i>Druckbereich</i> <i>Gamme de pression</i> <i>Rango de presión</i> <i>Range de pressão</i>		0.0 ~ -101.3 kPa 0 ~ -1 Bar	0.000 ~ 1 MPa 0 ~ 10 Bar		
Range di settaggio pressione <i>Set pressure range</i> <i>Einstellung Druckbereich</i> <i>Plage de pressions de réglage</i> <i>Rango de ajuste presión</i> <i>Range de ajuste da pressão</i>		10.0 ~ -101.3 kPa 0,1 ~ -1 Bar	-0.100 ~ 1 MPa -1 ~ -10 Bar		
Resistenza a pressione <i>Withstand pressure</i> <i>Druckbeständigkeit</i> <i>Résistance à la pression</i> <i>Resistencia a la presión</i> <i>Resistência a pressão</i>		300 kPa 3 Bar	1.5 MPa 15 Bar		
Fluidi <i>Fluid</i> <i>Medien</i> <i>Fluide</i> <i>Fluido</i> <i>Fluidos</i>		Aria filtrata, non corrosiva / No gas infiammabile <i>Filtered air, Non-corrosive / Non-flammable gas</i> <i>Gefilterte Luft, nicht korrosiv / Kein brennbares Gas</i> <i>Air filtré, non corrosif / Gaz neutre</i> <i>Aire filtrado, no corrosivo / No gas inflamável</i> <i>Ar filtrado, não corrosivo / Não aplicável para gás inflamável</i>			
Settaggio unità di pressione <i>Set pressure resolution</i> <i>Einstellung Druckeinheiten</i> <i>Unité de réglage de pression</i> <i>Ajuste unidad de presión</i> <i>Ajuste de unidade de pressão</i>	kPa	0.1	-		
	MPa	-	0.001		
	kgf/cm ²	0.001	0.01		
	bar	0.001	0.01		
	psi	0.01	0.1		
	inHg	0.1	-		
Tensione di alimentazione <i>Power supply voltage</i> <i>Stromversorgungsspannung</i> <i>Tension d'alimentation</i> <i>Tensión de alimentación</i> <i>Tensão de alimentação</i>		12 to 24V DC ±10%, Ripple (P-P) 10% or less			
Consumo corrente <i>Current consumption</i> <i>Stromverbrauch</i> <i>Consumation</i> <i>Consumo actual</i> <i>Consumo de corrente</i>		≤ 40mA (With no load)			
Uscite <i>Switch output</i> <i>Ausgänge</i> <i>Sortie</i> <i>Salidas</i> <i>Saídas</i>		PNP: Connettore aperto 2 uscite <i>PNP: open collector 2 outputs</i> <i>PNP: offener Kollektor 2 Ausgänge</i> <i>PNP: 2 sorties NO</i> PNP: conector abierto 2 salidas <i>PNP: Coletor aberto 2 saídas</i>	Max. carico corrente: 125 mA <i>Max. load current: 125 mA</i> <i>Max. Laststrom: 125 mA</i> <i>Courant de charge max: 125 mA</i> Corrente carga máxima: 125 mA <i>Máx. Corrente de Carga: 125 mA</i>	Max. voltaggio: 24V DC <i>Max. supply voltage: 24V DC</i> <i>Max. Versorgungsspannung: 24V DC</i> Tension maximale: 24V DC <i>Voltaje Max: 24V DC</i> Tensão Máx: 24V DC	Voltaggio residuo: ≤ 1.5V <i>Residual voltage: ≤ 1.5V</i> <i>Restspannung: ≤ 1.5V</i> Tension résiduelle: ≤ 1.5V <i>Voltaje residual: ≤ 1.5V</i> Tensão Residual: ≤ 1.5V
Ripetibilità <i>Repeatability</i> <i>Répétitivité</i> <i>Répétabilité</i> <i>Repetibilidad</i> <i>Repetibilidade</i>		±0.2% FS ±1 digit			
Isteresi <i>Hysteresis</i> <i>Hysterese</i> <i>Hystérésis</i> <i>Histéresis</i> <i>Histerese</i>	Settaggio per punti <i>One point set mode</i> <i>Ein Punkt-Set-Modus</i> <i>Mode de réglage par point</i> <i>Ajuste por puntos</i> <i>Ajuste por pontos</i>		(*1) Regolabile <i>Adjustable</i> <i>Regulierbar</i> <i>Réglable</i> <i>Regulable</i> <i>Ajustável</i>		
	Modo isteresi <i>Hysteresis mode</i> <i>Hysterese-Modus</i> <i>Mode hystérésis</i> <i>Modo Histérésis</i> <i>Modo histerese</i>				
	Modo comparatore a finestra <i>Window comparator mode</i> <i>Fenster-Vergleichsmodus</i> <i>Mode Comparateur à fenêtre</i> <i>Modo comparador a ventana</i> <i>Modo de comparação de janela</i>				
Tempo di risposta <i>Response time</i> <i>Reaktionszeit</i> <i>Temps de réponse</i> <i>Tiempo de respuesta</i> <i>Tempo de resposta</i>		≤ 2.5ms (chattering-proof function: 25ms, 100ms, 250ms, 500ms, 1000ms, and 1500ms selectable)			
Protezione di cortocircuito uscite <i>Output short circuit protection</i> <i>Kurzschlusschutz am Ausgang</i> <i>Protection contre les court-circuits</i> <i>Protección de cortocircuito salida</i> <i>Proteção de curto-circuito nas saídas</i>		Yes			

MODEL		PR02 V (Vacuum)	PR02 P (Pressure)
Display LCD a 7 segmenti 7 segment LCD display LCD Anzeige mit 7 Segmenten Affichage LCD - 7 segments Display LCD a 7 segmentos Display LCD de 7 segmentos		3½ digit, 7 segment (red/green)	
Precisione sul display Indicator accuracy Genauigkeit in der Anzeige Précision sur l'affichage Precisión del display Precisão do display		±2% F.S. ±1 digit (ambient temperature: 25 ±3°C)	
Indicatore ON Switch ON Indicator Schalter ON Anzeige Indicateur ON Indicador ON Indicador ON		Orange (1&2 Indicator) OUT1 OUT2	
Uscita analogica (Voltaggio in uscita) (*2) Analog output (Voltage Output) (*2) Analogausgang (Spannungsausgang) (*2) Sortie analogique (Tension en sortie) (*2) Salida analógica (Voltaje en salida) (*2) Saída analógica (Tensão de saída) (*2)		Output Voltag: 1 to 5V ±2.5% F.S. (within rated pressure range) Linearity: ±1% F.S. Output impedance: about 1kΩ	
Uscita analogica (Corrente in uscita) (*3) Analog output (Current Output) (*3) Analogausgang (Stromausgang) (*3) Sortie Analogique (Courant en sortie) (*3) Salida analógica (Corriente en salida) (*3) Saída analógica (Corrente de saída) (*3)		Output Current: 4 to 20mA ±2.5% F.S. (within rated pressure range) Linearity: ±1% F.S. Max. Load Impedance: 250Ω at power supply of 12V, 600Ω at power supply of 24V Min. Load impedance: 50Ω	
Ambiente Environment Umgebung Environnement Ambiente Ambiente	Grado di protezione IP enclosure Schutzart Indice de protection Grado de protección Grau de proteção	IP 65	
	Range temperatura ambiente Ambient temp.range Umgebungstemperaturbereich Plage de température Rango temperatura ambiente Range de temp. ambiente	Operation: 0 ~ 50°C, Storage:-10 ~ 60°C (No condensation or freezing)	
	Range umidità ambiente Ambient humidity range Luftfeuchtigkeitsbereich Taux d'humidité Rango humedad ambiente Range de umidade ambiente	Operation/Storage: 35 ~ 85% RH (No condensation)	
	Tensione di tenuta Withstand voltage Spannungsfestigkeit Tension de maintien Tensión de cierre Tensão de retenção	1000V AC in 1-min (between case and lead wire)	
	Resistenza di isolamento Insulation resistance Isolationswiderstand Résistance Resistencia de aislamiento Resistência de isolamento	50MΩ. (at 500V DC, between case and lead wire)	
	Vibrazione Vibration Vibration Vibration Vibración Vibração	Total amplitude 1.5mm or 10G, 10Hz-55Hz-10Hz scan for 1 minute, two hours each direction of X, Y and Z	
	Urto Shock Schock Choc Choque Impacto	100m/s2 (10G), 3 times each in direction of X, Y and Z	
Caratteristica temperatura Temperature characteristic Temperaturcharakteristik Caractéristiques température Característica temperatura Característica de temperatura		±2.5% F.S. of detected pressure (25°C) at temp. Range of 0~50°C	
Misura attacco Port size Anschlussgröße Raccordement Medida conexión Tamanho de rosca		R1/8" - M5	
Cavi Lead wire Kabel Câble Cable Cabos		Oil-resistance cable (0.15 mm ²)	
Peso Weight Gewicht Poids Peso Peso		Approx. 86g (with 2 meter lead wire)	

*1: In modalità "settaggio per punti" e modalità "comparatore a finestra", l'isteresi può essere regolata da 1-8 cifre.
 *2: Se si seleziona l'uscita di tensione analogica, non è possibile selezionare l'uscita di corrente analogica.
 *3: Se si seleziona l'uscita di corrente analogica, non è possibile selezionare l'uscita di tensione analogica.
 *1: Hysteresis value is adjustable within 1 ~ 8 digits for one point set mode and window comparator mode.
 *2: If analog voltage output is selected, the analog current cannot be selected at the same time.
 *3: If analog voltage output is selected, the analog voltage cannot be selected at the same time.

*1: „Ein Punkt-Set-Modus“ und „Fenstervergleichs-Modus“, ist der Hysterese Wert einstellbar auf 1-8 Ziffern.
 *2: Wenn der analoge Spannungsausgang ausgewählt wird, kann kein analoger Stromausgang gewählt werden.
 *3: Wenn der analoge Stromausgang ausgewählt wird, kann kein analoger Spannungsausgang gewählt werden.
 *1: La valeur d'hystérésis est réglable de 1 ~ 8 chiffres pour un mode de réglage par point et le mode comparateur à fenêtre.
 *2: Si vous sélectionnez la sortie de tension analogique, vous ne pouvez pas sélectionner la sortie de courant analogique.
 *3: Si vous sélectionnez la sortie de courant analogique, vous ne pouvez pas sélectionner la sortie de tension analogique.

*1: En modalidad "Ajuste por puntos" y modalidad "comparador a ventana" la histeresis puede ser regulada de 1 a 8 cifras.
 *2: Si se selecciona la salida de tensión analógica, no es posible seleccionar la salida de corriente analógica.
 *3: Si se selecciona la salida de corriente analógica, no es posible seleccionar la salida de tensión analógica.
 *1: No modo "ajuste por puntos" e no modo "comparador por janela", a histerese pode ser regulada de 1-8 dígitos.
 *2: Se for selecionado saída por tensão analógica, não será possível escolher a saída de corrente analógica.
 *3: Se for selecionada a saída por corrente analógica, não será possível escolher a saída por tensão analógica.

